

ASME Y14.2-2014
(Revision of ASME Y14.2-2008)

Line Conventions and Lettering

**Engineering Drawing and Related
Documentation Practices**

AN AMERICAN NATIONAL STANDARD



**The American Society of
Mechanical Engineers**

ADOPTION NOTICE

ASME Y14.2, Line Conventions and Lettering, was adopted on 30 September 2008 for use by the Department of Defense (DoD). Proposed changes by DoD activities must be submitted to the DoD Adopting Activity: Commander, U.S. Army Research, Development and Engineering Center (ARDEC), ATTN: RDAR-EIQ-SE, Picatinny Arsenal, NJ 07806-5000. Copies of this document may be purchased from The American Society of Mechanical Engineers (ASME), Two Park Avenue, New York, NY 10016-5990; <http://www.asme.org>.

Custodians:

Army — AR
Navy — SA
Air Force — 16

Adopting Activity:
Army — AR

(Project DRPR-2008-006)

Review Activities:

Army — CR, IE, MI, PT, TM2
Navy — AS, CG, CH, EC, MC, NP, TD
Air Force — 13, 99
DLA — DH
OSD — SE
NSA — NS
Other — CM, MP, DC2

NOTE: The activities listed above were interested in this document as of the date of this document. Since organizations and responsibilities can change, you should verify the currency of the information above using the ASSIST Online database at <https://assist.dla.mil>.

ASMC N/A

AREA DRPR

DISTRIBUTION STATEMENT A. Approved for public release; distribution is unlimited.

ASME Y14.2-2014
[Revision of ASME Y14.2-2008]

Line Conventions and Lettering

**Engineering Drawing and Related
Documentation Practices**

AN AMERICAN NATIONAL STANDARD



**The American Society of
Mechanical Engineers**

Two Park Avenue • New York, NY • 10016 USA

Date of Issuance: January 30, 2015

This Standard will be revised when the Society approves the issuance of a new edition.

Periodically certain actions of the ASME Y14 Committee may be published as Cases. Cases are published on the ASME Web site under the Y14 Committee Page at go.asme.org/Y14committee as they are issued.

Errata to codes and standards may be posted on the ASME Web site under the Committee Pages to provide corrections to incorrectly published items, or to correct typographical or grammatical errors in codes and standards. Such errata shall be used on the date posted.

The Y14 Committee Page can be found at go.asme.org/Y14committee. There is an option available to automatically receive an e-mail notification when errata are posted to a particular code or standard. This option can be found on the appropriate Committee Page after selecting “Errata” in the “Publication Information” section.

ASME is the registered trademark of The American Society of Mechanical Engineers.

This code or standard was developed under procedures accredited as meeting the criteria for American National Standards. The Standards Committee that approved the code or standard was balanced to assure that individuals from competent and concerned interests have had an opportunity to participate. The proposed code or standard was made available for public review and comment that provides an opportunity for additional public input from industry, academia, regulatory agencies, and the public-at-large.

ASME does not “approve,” “rate,” or “endorse” any item, construction, proprietary device, or activity.

ASME does not take any position with respect to the validity of any patent rights asserted in connection with any items mentioned in this document, and does not undertake to insure anyone utilizing a standard against liability for infringement of any applicable letters patent, nor assumes any such liability. Users of a code or standard are expressly advised that determination of the validity of any such patent rights, and the risk of infringement of such rights, is entirely their own responsibility.

Participation by federal agency representative(s) or person(s) affiliated with industry is not to be interpreted as government or industry endorsement of this code or standard.

No part of this document may be reproduced in any form,
in an electronic retrieval system or otherwise,
without the prior written permission of the publisher.

The American Society of Mechanical Engineers
Two Park Avenue, New York, NY 10016-5990

Copyright © 2015 by
THE AMERICAN SOCIETY OF MECHANICAL ENGINEERS
All rights reserved
Printed in U.S.A.

.....

CONTENTS

Foreword	iv
Committee Roster	v
Correspondence With the Y14 Committee	vi
1 General	1
2 References	2
3 Definitions	2
4 Line Conventions	3
5 Arrowheads	5
6 Lettering	5
Figures	
3-1 Line Widths and Types	7
4-1 Applications of Lines	8
4-2 Hidden Line Techniques and Symmetry Line Application	9
4-3 Section Lining of Adjacent Parts	9
4-4 Direction of Section Lines	10
4-5 Full Section	10
4-6 Outline Section Lining	10
4-7 Arrowhead Placement on Dimension Lines	11
4-8 Special Applications of Extension Lines	11
4-9 Termination of Leaders	12
4-10 Phantom Line Applications	13
5-1 Arrowhead Styles	14
6-1 Inclined Letters	14
6-2 Vertical Letters	15
Table	
6-1 Minimum Letter Height Proportions	15

FOREWORD

This Standard is a revision of ASME Y14.2-2008, Line Conventions and Lettering. The successful revision of this Standard is attributed to the Subcommittee members and their respective companies who participated in the review process.

The more substantial changes are as follows:

(a) Due to the addition of the Y14 Policy 3 statements, all the paragraphs and figures were renumbered.

(b) Examples for leaders for datum targets were added to Fig. 4-9.

(c) A datum target line was added as an example of a phantom line.

(d) The width of a dimensional arrow is constrained to the width of the dimension line.

(e) Letter height has changed from specific heights to proportions of the letter height.

Suggestions for improvement of this Standard are welcome, and should be sent to The American Society of Mechanical Engineers; Attention: Secretary, Y14 Standards Committee; Two Park Avenue, New York, NY 10016-5990.

This Standard was approved as an American National Standard on December 8, 2014.

ASME Y14 COMMITTEE

Engineering Drawing and Related Documentation Practices

(The following is the roster of the Committee at the time of approval of this Standard.)

STANDARDS COMMITTEE OFFICERS

W. A. Kaba, *Chair*
J. I. Miles, Sr., *Vice Chair*
F. Constantino, *Secretary*

STANDARDS COMMITTEE PERSONNEL

A. R. Anderson , Dimensional Dynamics, LLC	A. Krulikowski , Effective Training, Inc.
F. Bakos, Jr. , Consultant	E. F. McCarthy , Raytheon Missile Systems
J. V. Burleigh , Unaffiliated	P. J. McCuiston , Multimac
F. Constantino , The American Society of Mechanical Engineers	J. D. Meadows , James D. Meadows & Associates, Inc.
D. E. Day , TEC-EASE, Inc.	M. E. Mero , Northrop Grumman Corp.
K. Dobert , Siemens PLM Software	J. I. Miles, Sr. , Lockheed Martin Aeronautics Co.
B. A. Harding , Purdue University	H. W. Oakes , U.S. Air Force (Peerless Technologies Corp.)
D. H. Honsinger , Consultant	N. Smith , Tucana Engineering, LLC
R. C. Jensen , Hexagon Metrology, Inc.	M. J. Stahl , Caterpillar, Inc.
W. A. Kaba , Spirit AeroSystems, Inc.	B. A. Wilson , The Boeing Co.
	K. E. Wiegandt , <i>Contributing Member</i> , Consultant

SUBCOMMITTEE 2 — LINE CONVENTIONS AND LETTERING

P. J. McCuiston , <i>Chair</i> , Multimac	J. G. Dadez , Applied Geometrics, Inc.
J. V. Burleigh , Unaffiliated	M. E. Foster , Applied Geometrics, Inc.
R. G. Campbell , Harper College	J. I. Miles, Sr. , Lockheed Martin Aeronautics Co.
R. R. Cruz , GE Aviation	R. H. Settle , Naval Surface Warfare Center, Dahlgren Division

CORRESPONDENCE WITH THE Y14 COMMITTEE

General. ASME Standards are developed and maintained with the intent to represent the consensus of concerned interests. As such, users of this Standard may interact with the Committee by requesting interpretations, proposing revisions or a Case, and attending Committee meetings. Correspondence should be addressed to:

Secretary, Y14 Standards Committee
The American Society of Mechanical Engineers
Two Park Avenue
New York, NY 10016-5990
<http://go.asme.org/Inquiry>

Proposing Revisions. Revisions are made periodically to the Standard to incorporate changes that appear necessary or desirable, as demonstrated by the experience gained from the application of the Standard. Approved revisions will be published periodically.

The Committee welcomes proposals for revisions to this Standard. Such proposals should be as specific as possible, citing the paragraph number(s), the proposed wording, and a detailed description of the reasons for the proposal, including any pertinent documentation.

Proposing a Case. Cases may be issued for the purpose of providing alternative rules when justified, to permit early implementation of an approved revision when the need is urgent, or to provide rules not covered by existing provisions. Cases are effective immediately upon ASME approval and shall be posted on the ASME Committee Web page.

Requests for Cases shall provide a Statement of Need and Background Information. The request should identify the Standard and the paragraph, figure, or table number(s), and be written as a Question and Reply in the same format as existing Cases. Requests for Cases should also indicate the applicable edition(s) of the Standard to which the proposed Case applies.

Attending Committee Meetings. The Y14 Standards Committee regularly holds meetings and/or telephone conferences that are open to the public. Persons wishing to attend any meeting and/or telephone conference should contact the Secretary of the Y14 Standards Committee. Future Committee meeting dates and locations can be found on the Committee Page at go.asme.org/Y14committee.

LINE CONVENTIONS AND LETTERING

1 GENERAL

1.1 Scope

This Standard establishes the line and lettering practices for use in the preparation of drawings, including the recognition of the requirements for computer aided design (CAD) and manually prepared drawings. When no exception or additional requirements are stated, existing ASME standards shall apply.

1.2 ASME Y14 Series Conventions

The conventions in paras. 1.2.1 through 1.2.10 are used in this and other ASME Y14 standards.

1.2.1 Mandatory, Recommended, Guidance, and Optional Words

- (a) The words "shall" and "will" establish a mandatory requirement.
- (b) The word "should" establishes a recommended practice.
- (c) The word "may" establishes an optional practice.
- (d) The words "typical," "example," "for reference," or the Latin abbreviation "e.g." indicate suggestions given for guidance only.
- (e) The word "or" used in conjunction with a mandatory requirement or a recommended practice indicates that there are two or more options for complying with the stated requirement or practice.

1.2.2 Cross-Reference of Standards. Cross-reference of standards in text with or without a date following the standard designator shall be interpreted as follows:

- (a) Reference to other ASME Y14 standards in the text without a date following the standard designator indicates that the issue of the standard identified in the References section (section 2) shall be used to meet the requirement.
- (b) Reference to other ASME Y14 standards in the text with a date following the standard designator indicates that only that issue of the standard shall be used to meet the requirement.

1.2.3 Invocation of Referenced Standards. The following examples define the invocation of a standard when specified in the References section (section 2) and referenced in the text of this Standard:

- (a) When a referenced standard is cited in the text with no limitations to a specific subject or paragraph(s) of the standard, the entire standard is invoked. For example, "Dimensioning and tolerancing shall be in accordance with ASME Y14.5" is invoking the complete standard because the subject of the standard is dimensioning and tolerancing and no specific subject or paragraph(s) within the standard are invoked.
- (b) When a referenced standard is cited in the text with limitations to a specific subject or paragraph(s) of the standard, only the paragraph(s) on that subject is invoked. For example, "Assign part or identifying numbers in accordance with ASME Y14.100" is invoking only the paragraph(s) on part or identifying numbers because the subject of the standard is engineering drawing practices and part or identifying numbers is a specific subject within the standard.
- (c) When a referenced standard is cited in the text without an invoking statement such as "in accordance with," the standard is for guidance only. For example, "For gaging principles see ASME Y14.43" is only for guidance and no portion of the standard is invoked.

1.2.4 Parentheses Following a Definition. When a definition is followed by a standard referenced in parentheses, the standard referenced in parentheses is the source for the definition.

1.2.5 Notes. Notes depicted in this Standard in ALL UPPERCASE letters are intended to reflect actual drawing entries. Notes depicted in initial uppercase or lowercase letters are to be considered supporting data to the contents of this Standard and are not intended for literal entry on drawings. A statement requiring the addition of a note with the qualifier "such as" is a requirement to add a note, and the content of the note is allowed to vary to suit the application.

1.2.6 Acronyms and Abbreviations. Acronyms and abbreviations are spelled out the first time used in this Standard followed by the acronym or abbreviation in parentheses. The acronym is used thereafter throughout the text.

1.2.7 Units. The International System of Units (SI) is featured in this Standard. It should be understood that U.S. Customary units could equally have been used without prejudice to the principles established.

1.2.8 Figures. The figures in this Standard are intended only as illustrations to aid the user in understanding the practices described in the text. In some cases figures show a level of detail as needed for emphasis. In other cases, figures are incomplete by intent so as to illustrate a concept or facet thereof. The absence of figure(s) has no bearing on the applicability of the stated requirements or practice. To comply with the requirements of this Standard, actual data sets shall meet the content requirements set forth in the text. To assist the user of this Standard, a listing of the paragraph(s) that refer to an illustration appears in the lower right-hand corner of each figure. This listing may not be all inclusive. The absence of a listing is not a reason to assume inapplicability. Some figures are illustrations of models in a three-dimensional environment. Figures illustrating drawings in digital format have a border included. When the letter “h” is used in figures for letter heights or for symbol proportions, select the applicable letter height in accordance with para. 6.4.

1.2.9 Precedence of Standards. The following are ASME Y14 standards that are basic engineering drawing standards:

ASME Y14.1	Decimal Inch Drawing Sheet Size and Format
ASME Y14.1M	Metric Drawing Sheet Size and Format
ASME Y14.2	Line Conventions and Lettering
ASME Y14.3	Orthographic and Pictorial Views
ASME Y14.5	Dimensioning and Tolerancing
ASME Y14.24	Types and Applications of Engineering Drawings
ASME Y14.34	Associated Lists
ASME Y14.35	Revision of Engineering Drawings and Associated Documents
ASME Y14.36M	Surface Texture Symbols
ASME Y14.38	Abbreviations and Acronyms for Use on Drawings and Related Documents
ASME Y14.41	Digital Product Definition Data Practices
ASME Y14.100	Engineering Drawing Practices

All other ASME Y14 standards are considered specialty types of standards and contain additional requirements or make exceptions to the basic standards as required to support a process or type of drawing.

1.2.10 Unless Otherwise Specified (UOS). The phrase “unless otherwise specified” or UOS is used to indicate a default requirement. The phrase is used when the default is a generally applied requirement and an exception may be provided by another document or requirement.

2 REFERENCES

The following revisions of American National Standards form a part of this Standard to the extent specified herein. A more recent revision may be used provided there is no conflict with the text of this Standard. In the event of a conflict between the text of this Standard and the references cited herein, the text of this Standard shall take precedence.

ASME Y14.3-2012, Orthographic and Pictorial Views

ASME Y14.5-2009, Dimensioning and Tolerancing

Publisher: The American Society of Mechanical Engineers (ASME), Two Park Avenue, New York, NY 10016-5990;
Order Department: 22 Law Drive, P.O. Box 2900, Fairfield, NJ 07007-2900 (www.asme.org)

3 DEFINITIONS

For definitions and illustrations of line types, see Fig. 3-1.

4 LINE CONVENTIONS

Line conventions describe the size, construction, and application of the various lines used in making drawings. Paragraphs 4.1 through 4.14 identify the type and style of lines for use on drawings.

4.1 Line Widths

Two widths of lines should be used on drawings (see Fig. 3-1). The ratio of line widths should be two-to-one (2:1). Recommended line widths are 0.3 mm minimum for thin lines and 0.6 mm minimum for thick lines. All lines of the same type shall be uniform throughout the drawing.

4.2 Line Spacing

Spacing between parallel lines may be exaggerated to a maximum of 3 mm, so there is no fill-in when the drawing is reproduced.

4.3 Visible Lines

Visible lines are continuous and shall be used for representing visible edges or contours of objects (see Figs. 3-1 and 4-1).

4.4 Projection Lines

When used, projection lines indicate the line of sight between two successive orthographic views. See ASME Y14.3.

4.5 Hidden Lines

When used, hidden lines represent hidden edges and contours. They consist of short evenly spaced dashes and are used to show the hidden features of an object. See Figs. 3-1 and 4-1. The length of the dashes may vary slightly in relation to the scale of the view.

Hidden lines should begin and end with a dash in contact with the visible or hidden line from which they start or end, except when such a dash would form a continuation of a visible line or when a CAD system has limitations that cannot comply with these requirements. Dashes should join at corners, and arcs should start with dashes at tangent points. See Fig. 4-2.

When features located behind transparent materials are depicted, they shall be treated as concealed features and shown with hidden lines. Hidden lines should be omitted when their use is not required for the clarity of the drawing.

4.6 Section Lines

When used, section lines show surfaces cut by a cutting plane. They are drawn as a pattern of straight, equally spaced, parallel lines used to indicate the cut surfaces of an object in section views. See Figs. 3-1 and 4-1.

4.6.1 General Principles. Cut surfaces of sectional views may be identified by using section lines. Section lines are optional and may be used when necessary to distinguish individual components of an assembly or to distinguish different surface levels of a full or partial section through a part. See ASME Y14.3.

Lettering should not be placed in section areas. However when it is unavoidable, the section lines shall be omitted in the area for the lettering. When several adjacent parts are shown in a section view, the parts may be sectioned as shown in Fig. 4-3. For section views of thin materials, see ASME Y14.3.

4.6.2 Direction and Spacing. Section lines should be drawn at a 45-deg angle within the view. See Fig. 4-3, illustration (a). On adjacent parts, the section lines should be drawn in the opposite direction. See Fig. 4-3, illustration (b). For additional adjacent parts, any suitable angle may be used to make each part stand out separately and clearly. See Fig. 4-3, illustration (c). A suitable angle should be chosen to avoid section lines that are parallel or perpendicular to visible lines. See Fig. 4-4. Section lines shall not meet at common boundaries.

Section lines shall be uniformly spaced a minimum of 1.5 mm, and spaced as generously as possible and yet preserve the unity and contrast of the sectioned areas. See Fig. 4-5.

Outline section lines are drawn adjacent to the boundaries only of the sectioned area, and may be used for large areas when section lines are required, provided clarity is not sacrificed. See Fig. 4-6.

4.7 Center Lines

When used, center lines represent axes, center points, or center planes of symmetrical parts and features, bolt circles, and paths of motion. See Figs. 4-1 and 4-2.

Center lines shall start and end with long lines and shall intersect by crossing the long lines or short dashes. See Fig. 3-1. The long line portion of the center line may vary in length depending on the scale of the view. Center lines shall extend uniformly and distinctly a short distance beyond the object or feature. The center line may be extended for dimensioning or for some other purpose.

Center lines shall not extend through the space between views. Short center lines may be unbroken when no confusion results with other lines.

4.8 Symmetry Lines

Symmetry lines are used to identify a plane of symmetry. The plane of symmetry is identified by placing two short parallel lines (symmetry lines), drawn at right angles, crossing a center line near each end and outside the boundary of the part. See Fig. 3-1.

Symmetry lines are used when representing partially drawn views and partial sections of symmetrical parts. See Fig. 4-2. Visible and hidden lines in symmetrical views may extend past the center line when clarity is improved.

4.9 Dimension, Extension, and Leader Lines

These are solid lines used to dimension drawings as described in paras. 4.9.1 through 4.9.3.2. See ASME Y14.5.

4.9.1 Dimension Lines. Dimension lines are used to indicate the extent and direction of dimensions, and are terminated with uniform arrowheads. See Figs. 3-1 and 4-1. Arrowheads shall be drawn within the limits of the extension lines when possible. See Fig. 4-7, illustration (a). When inadequate space is available, the dimension lines and arrowheads may be shown outside the extension lines. See Fig. 4-7, illustration (b).

4.9.2 Extension Lines. Extension lines are used to indicate

- (a) the point or line on the drawing to which the dimension applies. See Figs. 3-1 and 4-1.
- (b) the extension of a surface to a theoretical intersection. See Fig. 4-8.

4.9.3 Leader Lines. When used, leader lines direct notes, dimensions, symbols, item numbers, or part numbers on the drawing. See Figs. 3-1 and 4-1. A leader line should be a straight inclined line, except for a short horizontal portion extending to the center of the height of the first or last letter or character of the note. Leader lines may consist of one or more line segments [see Fig. 4-9, illustrations (d), (e), and (f)] or two line segments [see Fig. 4-9, illustrations (a), (b), and (c)]. Leaders may be drawn with a hidden line style when pointing to a hidden surface. The horizontal portion of the leader shall not underline the note, and may be omitted entirely.

A vertical line may be used at the end of the leader to group information. When the vertical line is used, the leader line may terminate at any point on the vertical line.

4.9.3.1 Terminate leaders as follows:

- (a) without a terminator, when they end on a dimension line. See Fig. 4-9, illustration (a).
- (b) with a dot 1.5 mm minimum diameter, when they end within outlines of an object. See Fig. 4-9, illustration (b).
- (c) with an arrowhead, when they end on the outline of an object. See Fig. 4-9, illustration (c).
- (d) without a terminator for a datum target. See Fig. 4-9, illustrations (d), (e), and (f).

4.9.3.2 Leader lines

- (a) should not cross
- (b) should not be excessively long
- (c) shall not be parallel to adjacent dimension, extension, or section lines
- (d) shall not be drawn at small angles to terminating surfaces
- (e) shall not be vertical or horizontal

4.10 Cutting-Plane and Viewing-Plane Lines

When used, cutting-plane and viewing-plane lines indicate the location of cutting planes for sectional views and the viewing position for removed views. See Figs. 3-1 and 4-1. Cutting-plane and viewing-plane lines shall be drawn to stand out clearly on the drawing. The ends of the lines are at 90 deg, and terminated by arrowheads to indicate the direction of sight for viewing. See Fig. 4-1 and ASME Y14.3. Three forms of cutting-plane and viewing-plane lines are as follows:

- (a) evenly spaced dashes. See Fig. 3-1 (line 9).
- (b) alternating long dashes and pairs of short dashes. The long dashes may vary in length, depending on the size of the drawing. See Fig. 3-1 (line 10).
- (c) Figure 3-1 (line 11), same as lines 9 and 10, except the dashes between line ends are omitted.

4.11 Break Lines

Break lines are used when complete views are not required. The two forms of break lines are

- (a) freehand line. See Fig. 3-1 (line 12) and Fig. 4-9.
- (b) long lines joined by zigzags. See Fig. 3-1 (line 13) and Fig. 4-10, illustration (a).

4.12 Phantom Lines

When used, phantom lines indicate

- (a) alternate positions of moving parts. See Fig. 4-1.
- (b) reference parts. See Fig. 4-10, illustration (a).
- (c) repeated details. See Fig. 4-10, illustrations (b) and (c).
- (d) filleted and rounded corners. See Fig. 4-10, illustration (d).
- (e) a reference plane between adjacent orthographic views.
- (f) a datum target line and areas. See Fig. 4-9, illustrations (d) and (e).

Phantom lines consist of long lines separated by pairs of short dashes. Phantom lines should start and end with long lines which may vary in length depending on the size of the drawing. See Fig. 3-1 (line 14).

4.13 Stitch Lines

Stitch lines are used for indicating a sewing or stitching process. See Fig. 3-1 (lines 15 and 16). The two forms of stitch lines are as follows:

- (a) short dashes and spaces of equal lengths
- (b) dots approximately 0.3 mm diameter, and 3 mm apart

4.14 Chain Lines

Chain lines are used to indicate a surface or surface zone receiving additional treatment or consideration within limits specified on the drawing. See Fig. 4-1. They may also be used to indicate the height of a projected tolerance zone as defined in ASME Y14.5M. Chain lines consist of alternating longer lines and short dashes. See Fig. 3-1 (line 17). The lines shall start and end with the longer lines. The length of the line segments may vary slightly in relation to the scale of the view.

5 ARROWHEADS

Arrowheads are used to terminate dimension, leader, and cutting- and viewing-plane lines. See paras. 4.9.1, 4.9.3, and 4.10. Arrowhead length and width should be a ratio of approximately 3:1. The width of the arrowhead should be a minimum of three times the width of the line to which the arrowhead is attached. A single style of arrowhead shall be used throughout the drawing. See Fig. 5-1.

6 LETTERING

For clarity within this Standard, lettering means both letters and numerals. Paragraphs 6.1 through 6.6 identify the type and style of lettering for use on drawings.

6.1 Lettering Type

Lettering should be single stroke gothic, opaque, and well-spaced characters as shown in Figs. 6-1 and 6-2. When additions or revisions are made to a drawing, the original style of lettering shall be maintained.

6.2 Letter Style

Either inclined or vertical lettering is permissible. Only one style of lettering shall be used throughout a drawing. The preferred slope for the inclined characters is approximately 68 deg from the horizontal. See Fig. 6-1.

6.3 Letters — Uppercase and Lowercase

Uppercase letters shall be used for all lettering on drawings unless lowercase letters are required. See Figs. 6-1 and 6-2.

6.4 Letter Height

The minimum letter height proportions for various size drawings are shown in Table 6-1. A minimum letter height (h) of 3 mm or .12 in. is recommended.















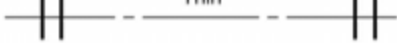

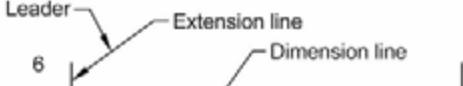
6.5 Letter Spacing

Letters in words should be spaced so the background areas between the letters are approximately equal, and words are clearly separated. The space between two numerals having a decimal point between them is to be a minimum of two-thirds the height of the lettering. The vertical space between lines of lettering shall be no more than the height of the lettering, or no less than half the height of the lettering.

6.6 Legibility

The lettering heights, spacing, and proportions in Figs. 6-1 and 6-2, and also Table 6-1, normally provide acceptable reproduction. If the recommended letter heights or proportions are not able to be met, the lettering is acceptable when the minimum legibility and reproduction requirements of the accepted industry or military reproduction specifications are met. Therefore, the basic requirement for lettering on a drawing is to produce fully legible copies.

Fig. 3-1 Line Widths and Types

Line Type	Line Style	Paragraph Reference
Visible line	1  Thick	4.3
Hidden line	2  Thin	4.5
Section line Projection line	3  Thin	4.4, 4.6
Center line	4  Thin	4.7
Symmetry line	5  Thin  Thick	4.8
Dimension line	6  Leader, Extension line, Dimension line	4.9.1
Extension line and Leader line	7  76	4.9.2
	8 Leader	4.9.3
Cutting-plane line or Viewing-plane line	9  Thick	4.10
	10  Thick	4.10
	11  Thick	4.10
Break line	12  Thick	4.11
	13  Thin	4.11
Phantom line Reference line	14  Thin	4.12
Stitch line	15  Thin	4.13
	16  Thin	4.13
Chain line	17  Thick	4.14

GENERAL NOTE:
 (a) **Line and Space Lengths** - Because of variances in drawing size and scale used, specifying the length and blank spaces for these line conventions is not practical. It is advisable to select the line and blank space length which depict the appropriate line convention commensurate with the drawing size and scale required.

4.14	4.13	4.12	4.11	4.10	4.9.3	4.9.2	4.9.1	4.8	4.7	4.6	4.5	4.3	4.1	3
------	------	------	------	------	-------	-------	-------	-----	-----	-----	-----	-----	-----	---

Fig. 4-1 Applications of Lines

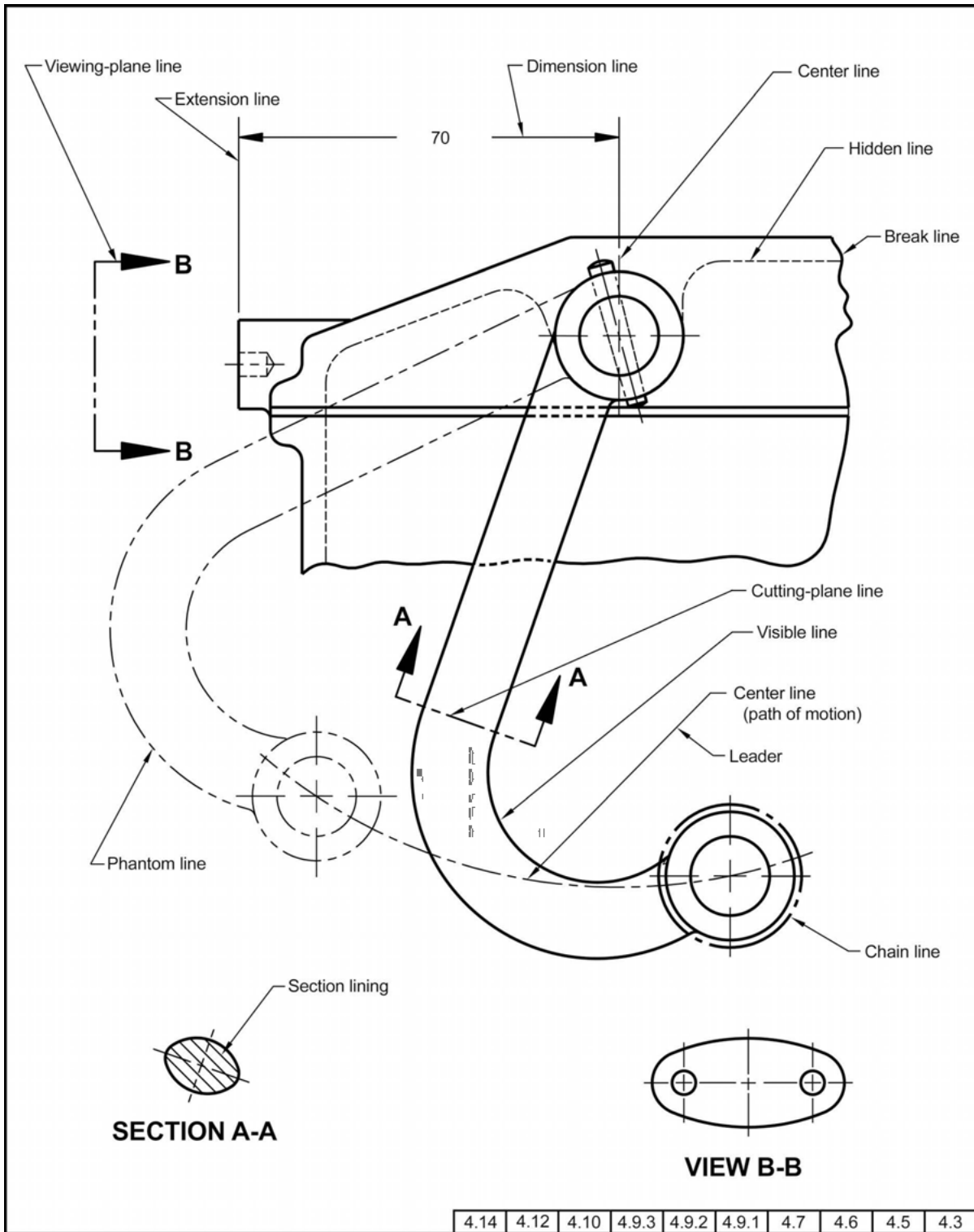

Fig. 4-2 Hidden Line Techniques and Symmetry Line Application

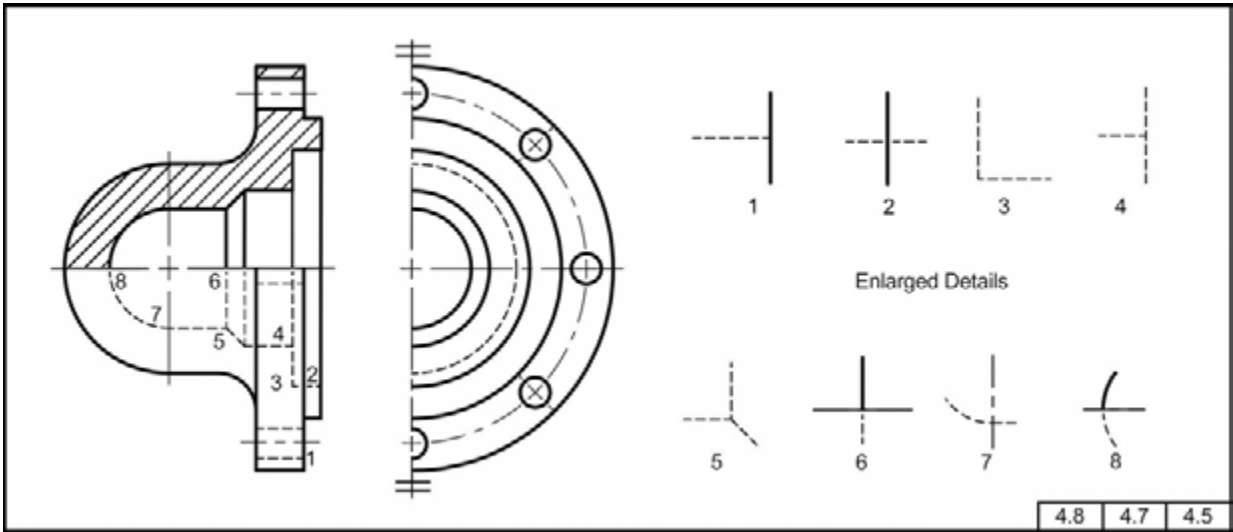

Fig. 4-3 Section Lining of Adjacent Parts

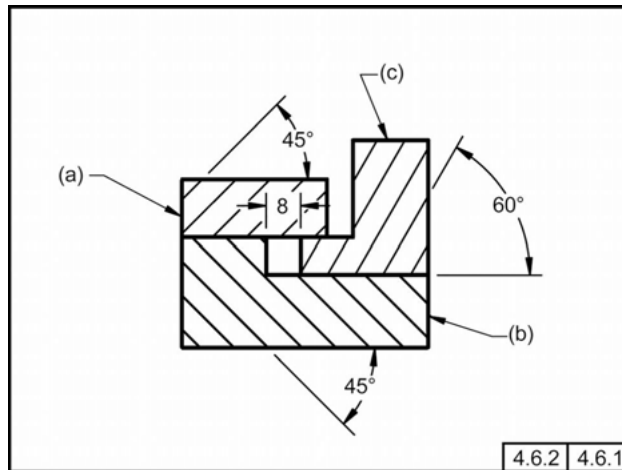

Fig. 4-4 Direction of Section Lines

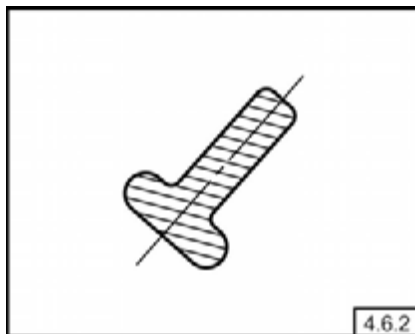

Fig. 4-5 Full Section

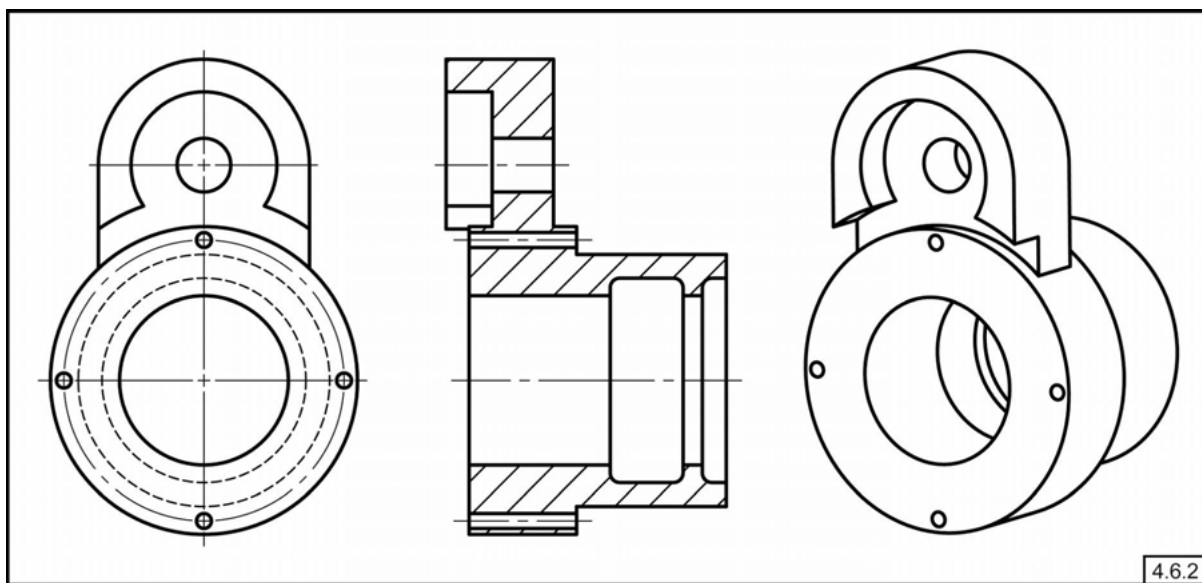

Fig. 4-6 Outline Section Lining

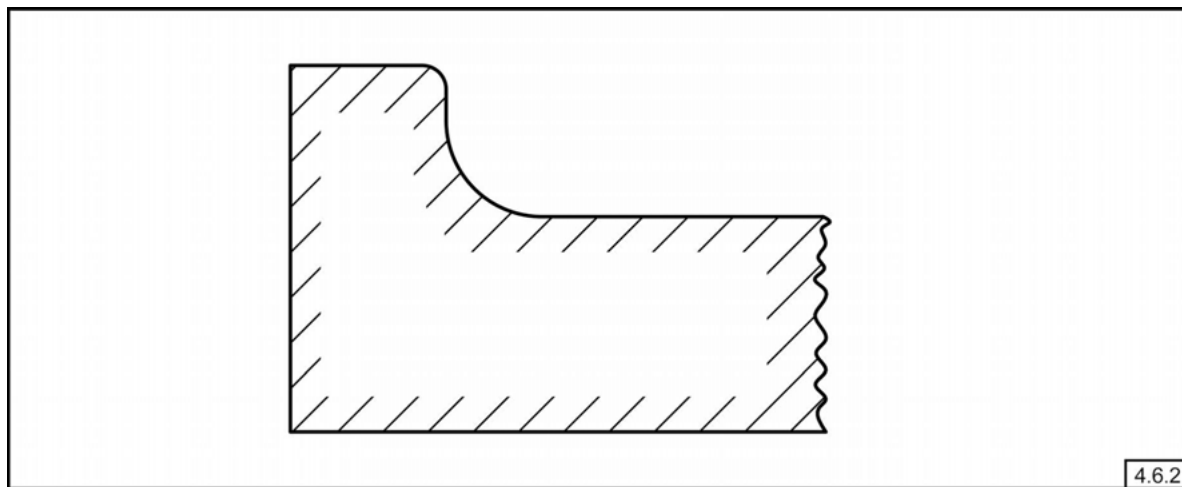

Fig. 4-7 Arrowhead Placement on Dimension Lines

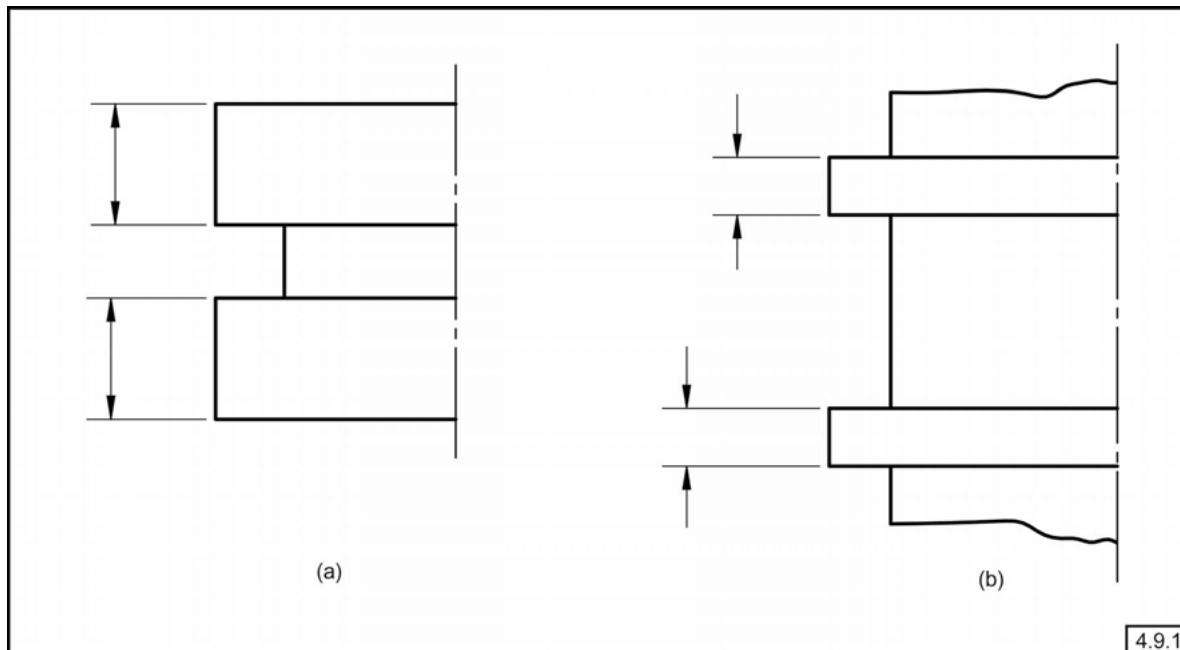

Fig. 4-8 Special Applications of Extension Lines

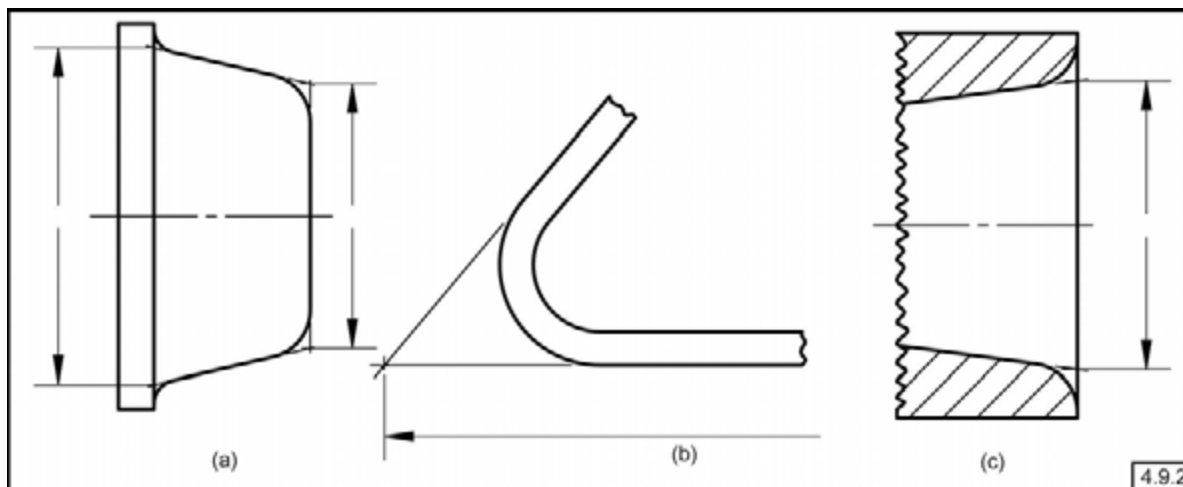

Fig. 4-9 Termination of Leaders

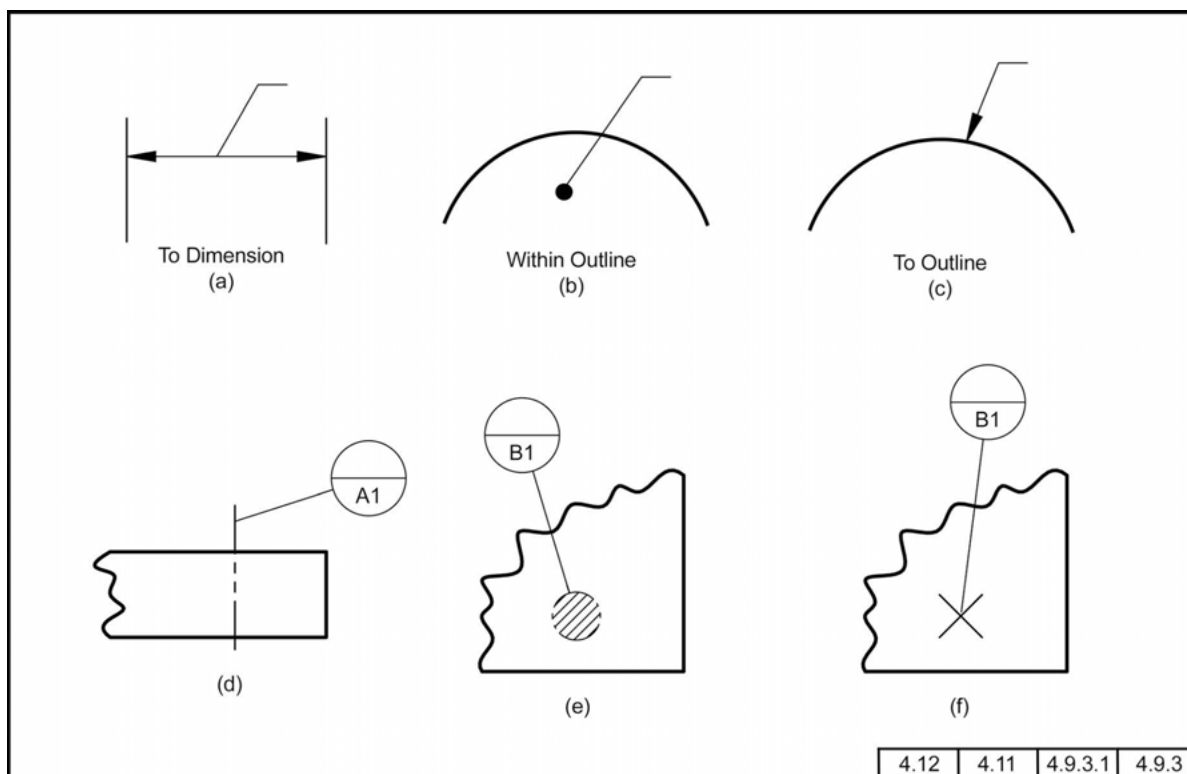

Fig. 4-10 Phantom Line Applications

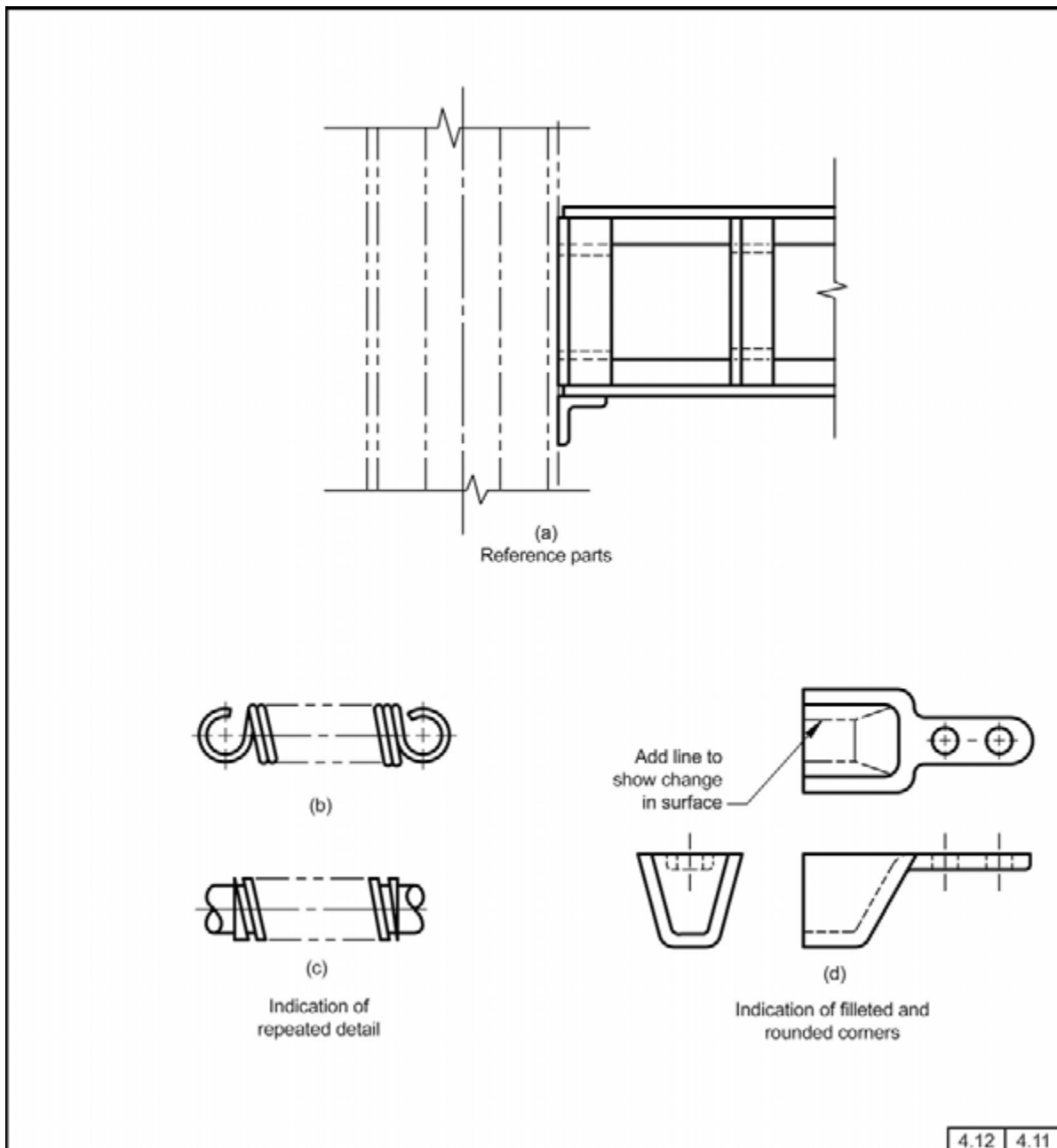

Fig. 5-1 Arrowhead Styles

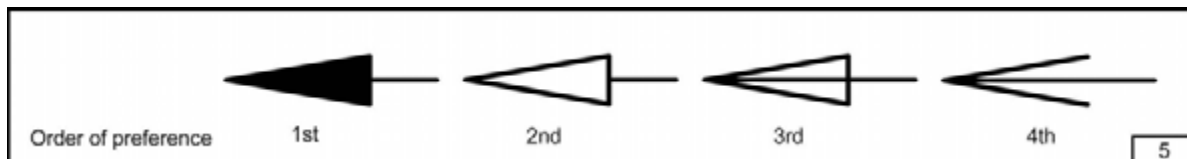

Fig. 6-1 Inclined Letters

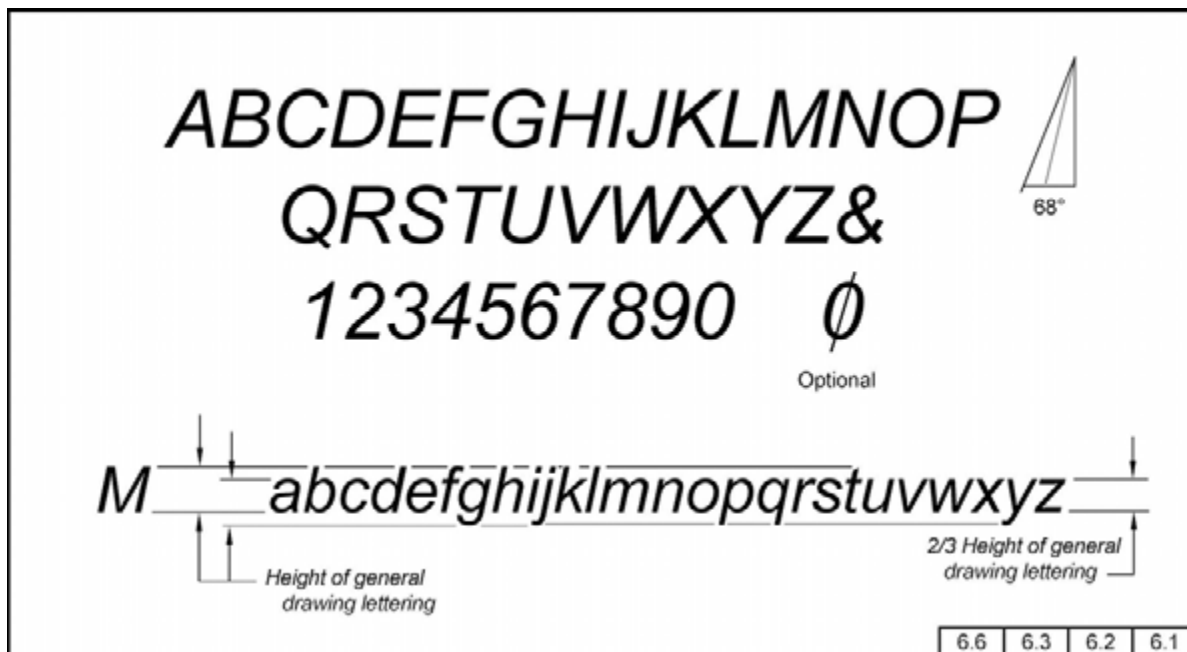

Fig. 6-2 Vertical Letters

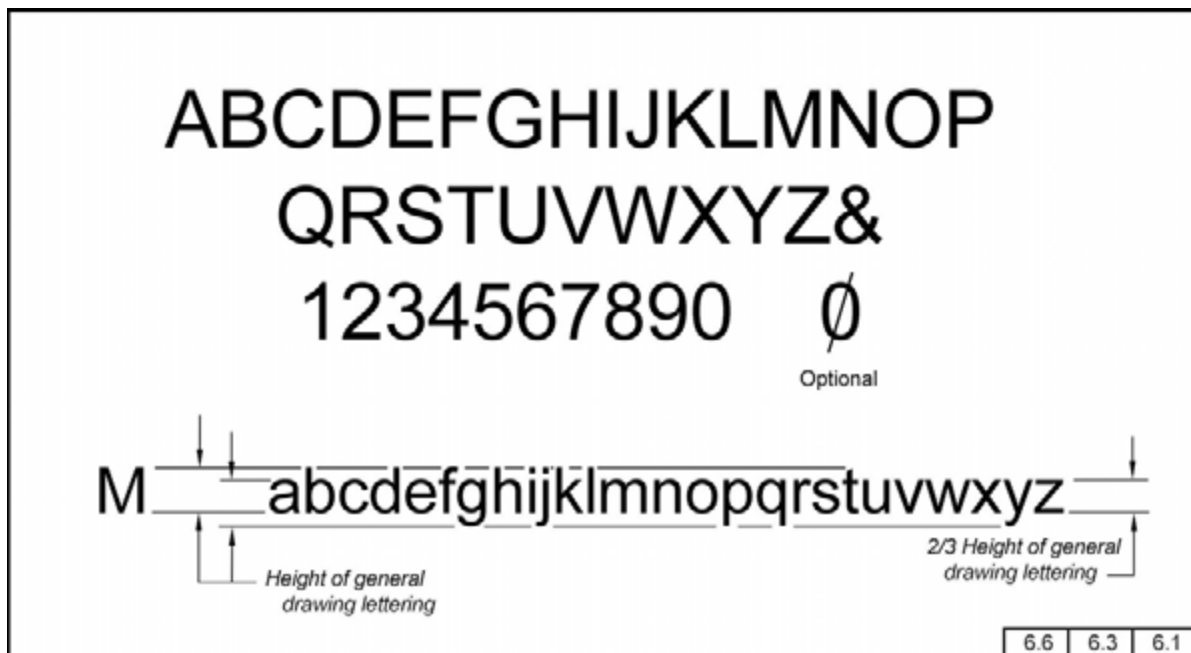

Table 6-1 Minimum Letter Height Proportions

Use for	Inch Drawing Size	Metric Drawing Size	Height Proportions
Drawing title, drawing size, CAGE code, drawing number, and revision letter [Note (1)]	D, E, F, H, J, K	A0, A1	2 × h
	A, B, C, G	A2, A3, A4	1 × h
Section and view letters	All	All	2 × h
Zone letters and numerals in borders	All	All	2 × h
Drawing block headings	All	All	.8 × h
Lowercase letters	All	All	.8 × h
All other characters	All	All	1 × h

NOTE:

(1) When used within the title block.

INTENTIONALLY LEFT BLANK

Y14 ENGINEERING DRAWING AND RELATED DOCUMENTATION PRACTICES

Decimal Inch Drawing Sheet Size and Format	Y14.1-2012
Metric Drawing Sheet Size and Format	Y14.1M-2012
Line Conventions and Lettering	Y14.2-2014
Orthographic and Pictorial Views	Y14.3-2012
Dimensioning and Tolerancing	Y14.5-2009
Mathematical Definition of Dimensioning and Tolerancing Principles	Y14.5.1M-1994 (R2012)
Certification of Geometric Dimensioning and Tolerancing Professionals	Y14.5.2-2000
Screw Thread Representation	Y14.6-2001 (R2013)
Castings, Forgings, and Molded Parts	Y14.8-2009
Types and Applications of Engineering Drawings	Y14.24-2012
Undimensioned Drawings	Y14.31-2014
Associated Lists	Y14.34-2013
Revision of Engineering Drawings and Associated Documents	Y14.35-2014
Surface Texture Symbols	Y14.36M-1996 (R2008)
Composite Part Drawings	Y14.37-2012
Abbreviations and Acronyms for Use on Drawings and Related Documents	Y14.38-2007 (R2013)
Digital Product Definition Data Practices	Y14.41-2012
Dimensioning and Tolerancing Principles for Gages and Fixtures	Y14.43-2011
Reference Designations for Electrical and Electronics Parts and Equipment	Y14.44-2008 (R2014)
Engineering Drawing Practices	Y14.100-2013
Graphic Symbols for Railroad Maps and Profiles	Y32.7-1972 (R2009)
Symbols for Mechanical and Acoustical Elements as Used in Schematic Diagrams	Y32.18-1972 (R2013)

The ASME Publications Catalog shows a complete list of all the Standards published by the Society. For a complimentary catalog, or the latest information about our publications, call 1-800-THE-ASME (1-800-843-2763).

ASME Services

ASME is committed to developing and delivering technical information. At ASME's Customer Care, we make every effort to answer your questions and expedite your orders. Our representatives are ready to assist you in the following areas:

ASME Press
Codes & Standards
Credit Card Orders
IMechE Publications
Meetings & Conferences
Member Dues Status

Member Services & Benefits
Other ASME Programs
Payment Inquiries
Professional Development
Short Courses
Publications

Public Information
Self-Study Courses
Shipping Information
Subscriptions/Journals/Magazines
Symposia Volumes
Technical Papers

How can you reach us? It's easier than ever!

There are four options for making inquiries* or placing orders. Simply mail, phone, fax, or E-mail us and a Customer Care representative will handle your request.

Mail
ASME
22 Law Drive, Box 2900
Fairfield, New Jersey
07007-2900

Call Toll Free
US & Canada: 800-THE-ASME
(800-843-2763)
Mexico: 95-800-THE-ASME
(95-800-843-2763)
Universal: 973-882-1167

Fax—24 hours
973-882-1717
973-882-5155

E-Mail—24 hours
customercare@asme.org

* Customer Care staff are not permitted to answer inquiries about the technical content of this code or standard. Information as to whether or not technical inquiries are issued to this code or standard is shown on the copyright page. All technical inquiries must be submitted in writing to the staff secretary. Additional procedures for inquiries may be listed within.

INTENTIONALLY LEFT BLANK

ASME Y14.2-2014

ISBN 978-0-7918-6971-0

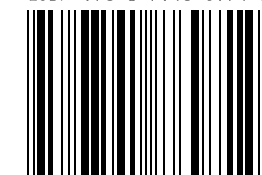

9 780791 869710



N00214